

SERIES 1000 SM-M

UL/ULC APPROVED
MODULATING SMOKE DAMPERS

engineering data
and specifications

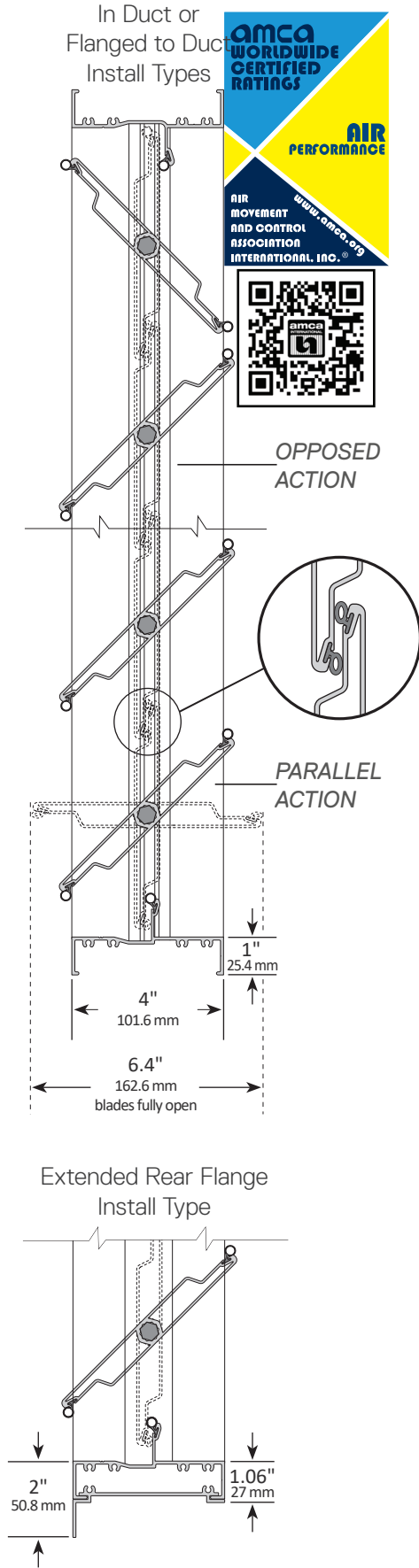



Leakage Rating:	Class 1
Operational Rating:	Airflow: 2000 fpm (10.2 m/s). Rated for airflow in either direction.
	Temperature: 250°F (121°C)
	Pressure: 4" w.g. (1 kPa) static pressure differential
Fail Position:	Closed

STANDARD CONSTRUCTION:

1. Extruded aluminum (6063-T5) smoke damper frame is not less than 0.080" (2.03 mm) in thickness. Damper frame is 4" (101.6 mm) deep x 1" (25.4 mm), with mounting flanges on both sides of frame. Damper frame has a 2" (50.8 mm) mounting flange on the rear of the damper, when ordered as Extended Rear Flange install type.
2. Blades are maximum 6" (152.4 mm) deep extruded aluminum (6063-T5) air-foil profiles. All blades are symmetrically pivoted.
3. Blade and frame seals are specially designed and engineered extruded silicone. Seals are secured in an integral slot within the aluminum extrusions. Blade and frame seals are mechanically fastened to prevent shrinkage and movement over the life of the damper.
4. Bearings are composed of a bronze oilite inner bearing - fixed around a 7/16" (11.11 mm) aluminum hexagon blade pivot pin - rotating within a bronze oilite outer bearing inserted in the frame.
5. The 7/16" (11.11 mm) hexagonal drive rod, U-bolt fastener, and hexagonal retaining nuts are zinc-plated steel. These provide a positive connection to blades and linkage.
6. Aluminum and corrosion-resistant zinc-plated steel linkage hardware is installed in the frame side, complete with cup-point trunnion screws for a slip-proof grip. Trunnion bearing is bronze oilite.
7. Smoke dampers are designed for operation in temperatures ranging from -40°F (-40°C) to 250°F (121°C).
8. Smoke dampers are custom made to required size, without blanking off free area. The blade stop is set at a fixed height and is a continuous and integral part of the top and bottom frames.
9. Smoke dampers are available with either opposed blade action or parallel blade action.

CONSTRUCTION OPTIONS:

For each option listed, replace the lines above with their corresponding lines below.

MR - MOISTURE RESISTANCE OPTION:

1. Extruded aluminum (6063-T5) smoke damper frame is not less than 0.080" (2.03 mm) in thickness. Damper frame is 4" (101.6 mm) deep x 1" (25.4 mm), with mounting flanges on both sides of frame. Damper frame has a 2" (50.8 mm) mounting flange on the rear of the damper, when ordered as Extended Rear Flange install type. Frame is assembled using stainless steel screws.
5. The 7/16" (11.11 mm) hexagonal drive rod, U-bolt fastener, and hexagonal retaining nuts are stainless steel. These provide a positive connection to blades and linkage.
6. Aluminum and stainless steel linkage hardware is installed in the frame side, complete with stainless steel cup-point trunnion screws for a slip-proof grip. Trunnion bearing is bronze oilite.

SW - SALT WATER RESISTANCE OPTION:

1. Extruded aluminum (6063-T5) smoke damper frame is not less than 0.080" (2.03 mm) in thickness. Damper frame is 4" (101.6 mm) deep x 1" (25.4 mm), with mounting flanges on both sides of frame. Damper frame has a 2" (50.8 mm) mounting flange on the rear of the damper, when ordered as Extended Rear Flange install type. Aluminum frame is clear anodized to a minimum depth of 0.7 mil (18 microns). Frame is assembled using stainless steel screws.
2. Blades are maximum 6" (152.4 mm) deep extruded aluminum (6063-T5) air-foil profiles, clear anodized to a minimum depth of 0.7 mil (18 microns). All blades are symmetrically pivoted.
5. The 7/16" (11.11 mm) hexagonal drive rod, U-bolt fastener, and hexagonal retaining nuts are stainless steel. These provide a positive connection to blades and linkage.
6. Clear anodized aluminum and stainless steel linkage hardware is installed in the frame side, complete with stainless steel cup-point trunnion screws for a slip-proof grip. Trunnion bearing is bronze oilite.

TAMCO® Series 1000 SM-M meets the requirements for smoke dampers established by:
 UL 555S/ULC-S112.1 File R16679
 National Fire Protection Association:
 NFPA Standards 80, 90A, 92, 101, 105
 California State Fire Marshall Listing#:
 3230-2116:0100





TAMCO® Series 1000 SM-M meets the requirements for smoke dampers established by:
UL 555S/ULC-S112.1 File R16679
National Fire Protection Association:
NFPA Standards 80, 90A, 92, 101, 105
California State Fire Marshall Listing#: 3230-2116:0100

MAXIMUM SINGLE-SECTION OPENING SIZE:	
36" w x 48" h	(915 mm x 1220 mm)
MAXIMUM MULTI-SECTION OPENING SIZES:	
144" w x 96" h	(3658 mm x 2438 mm)
288" w x 48" h	(7316 mm x 1220 mm)

INSTALLATION:

- Smoke dampers may be mounted vertically (*standing up/horizontal airflow*) with blades running horizontally, or mounted horizontally (*lying down/vertical airflow*).
- Dampers are available in four install types: Installed In Duct, Flanged to Duct, Extended Rear Flange, and Square to Round Transition. (*See Install Types pages for details.*)
- Multi-section smoke dampers may require field assembly of sections.
- Installation of dampers must be in accordance with TAMCO's current UL/ULC Approved Smoke Damper Installation Guidelines. (*Printed installation guidelines are provided with each damper shipment, however all technical information available on TAMCO's web site at www.tamcodampers.com supersedes information contained within printed versions.*)

ACTUATORS:

- UL 555S/ULC-S112.1 requires that all actuators for smoke dampers be factory mounted. Approved actuators are Belimo and Honeywell.
- Voltage: 24 vac/vdc, single phase and 2-10 vdc modulating control.
- Mounting: Internal or external actuator mounting. (*All smoke dampers with internally mounted actuators, will be mounted on a jackshaft. If actuator side of damper is to be connected to duct work, smoke damper assembly will have to be installed in a sleeve.*)
- Options: Auxiliary switches.
- Actuator quantity and location requirements are shown in, and must be in accordance with, TAMCO UL/ULC Approved Smoke Damper Configurations.

PERFORMANCE DATA | Series 1000 SM-M
UL/ULC Approved Modulating Smoke Damper

VELOCITY VS. PRESSURE DROP

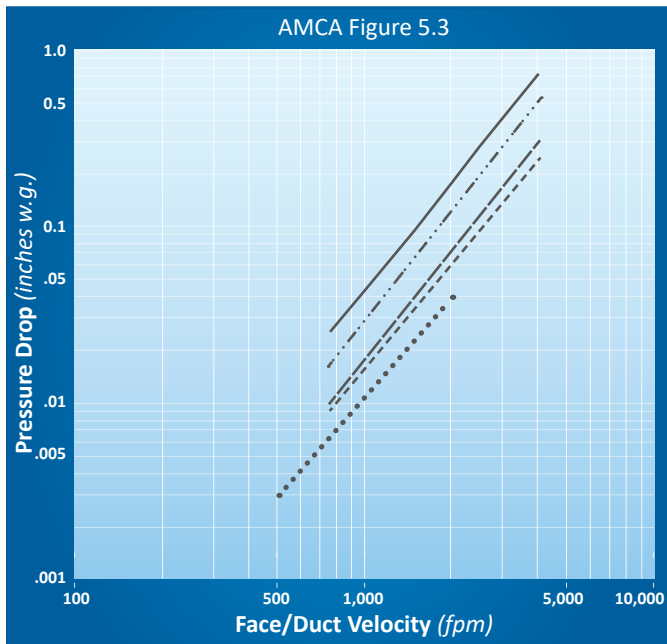

LEGEND:

12" x 12" ——— (305 mm x 305 mm)	24" x 24" - - - - (610 mm x 610 mm)	48" x 12" - · · · - (1220 mm x 305 mm)
12" x 48" ——— (305 mm x 1220 mm)	36" x 36" · · · · (915 mm x 915 mm)	

T.A. Morrison & Co. Inc. certifies that the TAMCO Series 1000 SM-M UL/ULC Approved Modulating Smoke Damper with no option, or with MR or SW Options shown herein is licensed to bear the AMCA Seal. The ratings shown are based on tests and procedures performed in accordance with AMCA Publication 511 and comply with the requirements of the AMCA Certified Ratings Program. The AMCA Certified Ratings Seal applies to air performance ratings.



FIG. 5.3 Test damper is fully ducted with a 5 diameter duct run upstream, and a 6 diameter duct run downstream. Pressure drop values are based on Flanged to Duct install type. Pressure drop will be greater for In Duct install type dampers.

INSTALL TYPES | Series 1000 SM-M
UL/ULC Approved Modulating Smoke Damper

- Always provide opening width and height dimensions, when ordering.
- Width dimension is always parallel to blades.
- Height dimension is always perpendicular to blades.

INSTALLED IN DUCT TYPE

- Finished damper O.D. is $\frac{1}{4}$ " (6.4 mm) less than opening width and height dimensions.

MINIMUM SECTION SIZE:	
11" w x 8.25" h	(280 mm x 210 mm)
MAXIMUM SECTION SIZE:	
12 ft ²	(1.1 m ²)
36" w x 48" h	(915 mm x 1220 mm)

INTERNAL ACTUATOR

Must be inserted in a sleeve or opening.

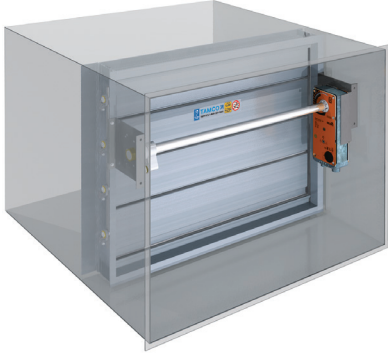

FLANGED TO DUCT TYPE

- Finished damper O.D. is 2" (50.8 mm) greater than opening width and height dimensions.

MINIMUM SECTION SIZE:	
11" w x 6" h	(280 mm x 153 mm)
MAXIMUM SECTION SIZE:	
12 ft ²	(1.1 m ²)
36" w x 48" h	(915 mm x 1220 mm)

EXTERNAL ACTUATOR

Both front and rear flanges can be mounted to opening surfaces.

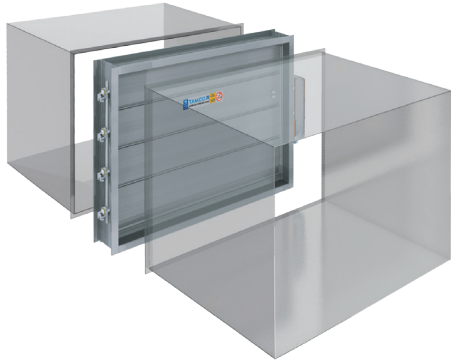

INTERNAL ACTUATOR

Only rear flange can be mounted to opening surface.

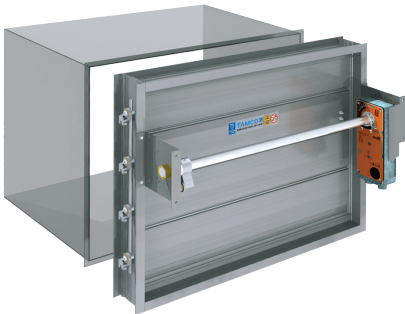

EXTENDED REAR FLANGE TYPE

- Finished damper O.D. is 4" (101.6 mm) greater than opening width and height dimensions.

MINIMUM SECTION SIZE:	
11" w x 6" h	(280 mm x 153 mm)
MAXIMUM SECTION SIZE:	
12 ft ²	(1.1 m ²)
36" w x 48" h	(915 mm x 1220 mm)

- Extended Rear Flange install type dampers are not designed so that the front of the damper may be inserted into an opening, as the side frame members extend to the full height of the rear flange.

EXTERNAL ACTUATOR

Both front and rear flanges can be mounted to opening surfaces.



INTERNAL ACTUATOR

Only rear flange can be mounted to opening surface.



SQUARE TO ROUND TRANSITION

- Always provide duct diameter dimension when ordering.
- If using TAMCO Connect software to submit orders, enter duct diameter dimension in both the width and height fields.
- Transition pieces are a minimum of 18 ga. galvanized steel for Series 1000 SM-M smoke dampers when ordered with no option.
- Transition pieces are 304 stainless steel, when Series 1000 SM-M smoke dampers are ordered with the MR or SW Options.
- Transition pieces and damper are sealed together.
- Dampers are built 4" (102 mm) larger than specified duct diameter. (Dampers are fabricated square.)
- Finished transition diameter is ¼" (6.35 mm) less than specified duct diameter, providing clearance for mating duct which slides over round transition. This ensures free movement of damper blades.

MINIMUM DUCT DIAMETER:	
9"	(229 mm)
MAXIMUM DUCT DIAMETER:	
58"	(1474 mm)
MAXIMUM SECTION SIZE:	
12 ft ²	(1.1 m ²)
MAXIMUM FINISHED OD:	
62" w x 62" h	(1575 mm x 1575 mm)

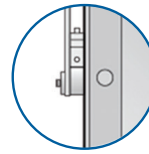
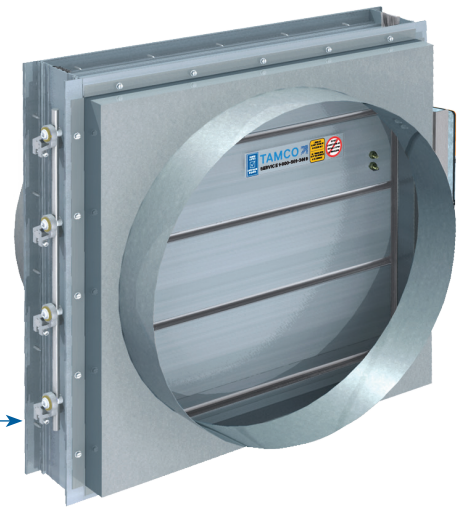

Linkage extends up to 1⁵/₁₆" (33 mm) beyond the outer edge of the transition.

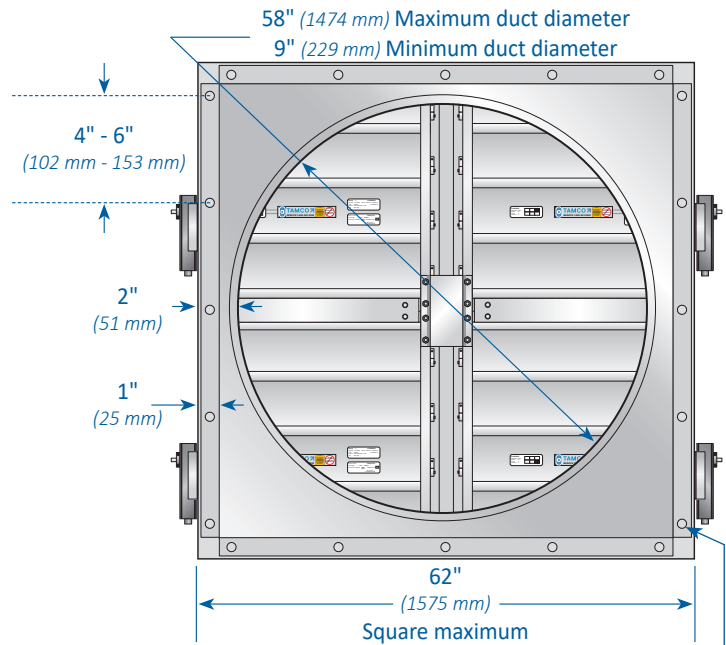
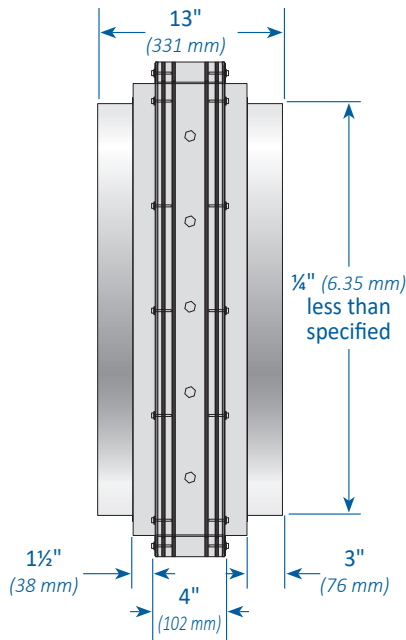

Transition attaches to damper frame or sleeve with minimum #8 sms screws, ¼" bolts, 3/16" rivets, or welds.

SERIES 1000 SM-M

ENGINEERING DATA AND SPECIFICATIONS

FOR ADDITIONAL INFORMATION REFER TO:



INSTALLATION GUIDELINES UNDER THE DOCUMENTS TAB:

- TAMCO UL/ULC Approved Smoke Damper Installation Guidelines
- TAMCO UL/ULC Approved Smoke Damper Jumper Installation Guidelines



INSTALLATION GUIDELINE VIDEOS

SPX ENGINEERED AIR MOVEMENT

80 Lorne Street
Smiths Falls, ON K7A 5J7, Canada
800 561 3449
tamcodampers.com

TA-1000SM-M-TECH-24 | ISSUED 01/2024
© 2024 SPX Engineered Air Movement | All rights reserved
In the interest of technological progress, all products are
subject to design and/or material change without notice.

SPX
TECHNOLOGIES